

EXTREEM SLAGVASTE VERLICHTING

Extreem slagvast en waterdicht



A2

Toepassingsgebieden



Parkeergarages



Portalen



Politiebureaus



Tunnels



Trappenhuisen



Gevangenis

Lichtkap: UV-gestabiliseerd polycarbonaat

Behuizing: aluminium, gecoat

Lichtbron: LED

IP 65

5 x IK 10



ENEC



* Optie

Afmetingen in mm:

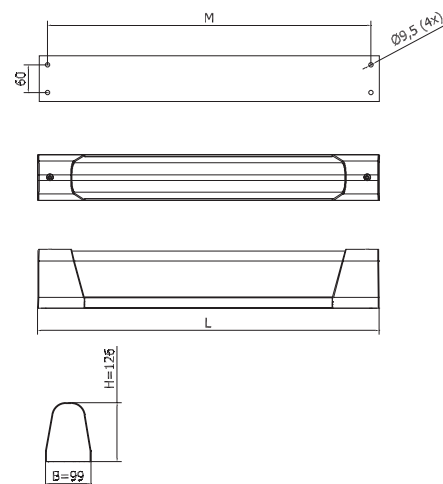

Technische specificaties



LUMEN LED	BEHUIZING	MAAT L (MM)	MAAT M (MM)
1100 / 1300 / 1600 / 1800 / 2000 / 2200 / 2500 / 2800 / 3100 / 3400 / 3600	2	736	700
3600 / 3900 / 4400 / 5000 / 6000 / 6500 / 7000 / 7500 / 8000	4	1346	1310

LED

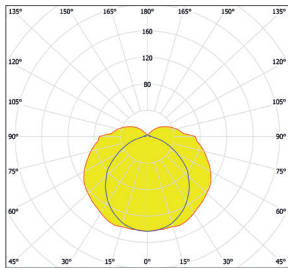

Productspecificaties

- lichtkap van 4 mm polycarbonaat, helder of opaal
- eindhaken van dubbel gecoat aluminium, wit (RAL 9010)
- aluminium behuizing dubbel gecoat, wit (RAL 9010)
- standaardsluiting met BZK-schroef (= binnenzeskschroef)
- montage-, installatie- en onderhoudsvriendelijk
- spanning: 230 / 240 V, 50 Hz
- RA-waarde: > 80
- kleurtemperatuur neutraal wit (4000K)
- verwachte levensduur HR: 100.000 (L70 / F10)

Opties

- noodverlichting (vanaf L 1346 mm)
- nacht loopverlichting
- andere RAL-kleur
- antigrffiticoating
- securityschroef HSS
- sleutel t.b.v securityschroef HSS
- JVA 3-pins schroef
- sleutel t.b.v JVA 3-pins schroef
- veiligheidsklasse II
- stuurfase
- 1-10V / Dali
- Constant Current
- Constant Lumen Output (CLO)
- kleurtemperatuur warm wit (3000K)

Bezoek onze website voor de meest actuele informatie:

www.lightronics.nl

